

B BUILT MFG

H-60 HYDRAULIC HAMMER



H-60 HYDRAULIC HAMMER

The B-Built Hydraulic Hammer can function as both a concrete chipper and a post driver.



Post Driver Application

As a post driver, you can quickly drive round or square fence posts, t-posts, pipe fence, median dividers, large tent spikes, sign posts, and a variety of other objects up to a 9" diameter.

Posts are driven into the ground with the jackhammering action of the unit. This vibrating action quickly drives a post into the ground, even through hard soil and some softer rock.

Using the 5" cup bit gives you control to drive the post straight and plumb.

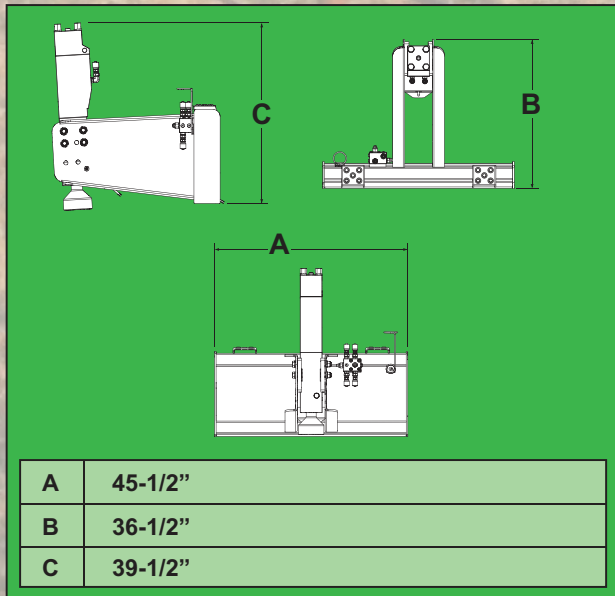

Hammer Application

You can quickly convert this unit into a chipping hammer by rotating the head 90 degrees and changing the bit. This hammer will make quick work out of breaking up concrete structures.

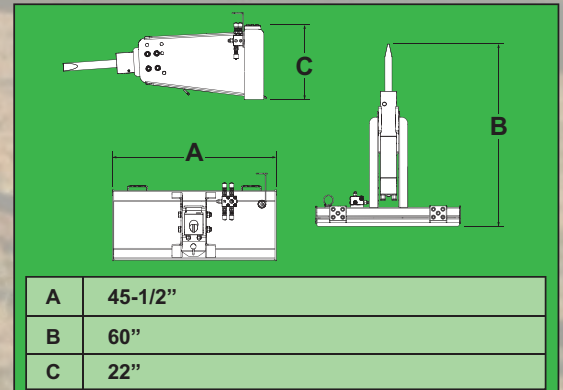

DESCRIPTION		SPECIFICATION
ENERGY (ft. lbs.)		600
OIL FLOW (GPM)		6 - 13
WORKING PRESSURE (psi)		1300 - 1740
WEIGHT		675 lbs.
BLOW RATE (Blows Per Minute)		550 - 1100
CHISEL SHAFT DIAMETER		2.36"
DOMED CUP DIAMETER		5"
DIMENSIONS	CUP POSITION	CHISEL POSITION
LENGTH	36-1/2"	60"
WIDTH	45-1/2"	45-1/2"
HEIGHT	39-1/2"	22"

Other Features and Accessories

Included with the unit is a tool box, which contains a grease gun, chisel bit, and drive pin for removing the chisel bit. For fencing applications, it includes a domed cup bit, t-post driver sleeve, two t-post pullers, and a plumb chain.



1550 Fairgrounds Road
Jefferson City, MO 65109
Brandon Bungart: 573-619-1973
Web: www.bbuiltmfg.com